



STEALTH

Designer

Innovative Ductless Mini Split Solution

Submittal Data: SC-42CD-UM / SC-42Z-UM

42000 BTUH Slim Duct Heat Pump System

Job Name Location Date

Purchaser Engineer

Submitted To For [ ] Reference [ ] Approval [ ] Construction

Unit Designation Schedule No.

GENERAL FEATURES

- Multi-Speed Fan
- Medium Static Pressure Capability
- Return Air From Rear Only
- Internal Condensate Drain Pump
- Sentry Condensate Overflow Protection
- Wired Remote Controllers
- Acrylic Resin/Anti-Corrosion Fin Coating



System Ratings

Cooling

Rated Capacity	39500 BTU/H
Capacity Range	12000-42500 BTU/H
Power Input (Max)	4700 W
SEER	16.0
EER	9.5

Heating at 47° F

Rated Capacity	44000 BTU/H
Capacity Range	13000-52500 BTU/H
Power Input (Max)	4750 W
HSPF	9.0
COP	3.3

Heating at 17° F

Rated Capacity	24800 BTU/H
----------------	-------------

Operating Range

Cooling	(Max)	118°F (48°C)
	(Min)	0°F (-18°C)
Heating	(Max)	75°F (24°C)
	(Min)	0°F (-18°C)

Refrigerant Piping Data

Gas Pipe Size (OD)	5/8-in
Liquid Pipe Size (OD)	3/8-in
Connection Method	Flared
Factory Charge	131.2 oz
Additional Charge	0.6 oz/ft
Pre-Charge Length	25-ft
MAX Refrigerant Pipe Length	164-ft
MIN Refrigerant Pipe Length	10-ft
MAX Refrigerant Pipe Elevation	49-ft

Indoor Unit Data

Fan Motor	Output Power	249 A
	FLA	2.1A
Airflow	Cooling Wet (Lo/Hi)	950/1175 CFM
	Heating Dry (Lo/Hi)	950/1175 CFM
Sound Level	Cooling (Min/Max)	45/53 dB(A)
	Heating (Min/Max)	45/53 dB(A)
Dehumidification		1.42 pt/hr
Condensate Drain Lift (Height)		33-in
Power Supply	Normal Operational Voltage	208/230 V, 1 Phase, 60 Hz
	Voltage Range	187 - 253 V
	Interconnecting Wire Size	18-2 AWG / 300V THHN
	MCA	3.0A
	MOCP/Breaker Size	15A

Outdoor Unit Data

Compressor		DC Inverter Driven Rotary
	RLA	21.2 A
Refrigerant Type		R410A
Fan Motor	Output Power	2 x 1/6HP
	FLA	2 x 2.0 A
Sound Level	Cooling/Heating	61/61 dB(A)
	Main Supply Wire Size	8 AWG
Power Supply	Normal Operational Voltage	208/230 V, 1 Phase, 60 Hz
	Voltage Range	187 - 253 V
	Main Supply Wire Size	8 AWG
	MCA	29.7 A
	MOCP/Breaker Size	50 A



**SYSTEM FEATURES**

Inverter Type	G10
Ultra Low Frequency Torque Control	YES
Power Factor Correction	YES
Compressor Type	Rotary
Refrigerant Type	R410A
Basepan With Electric Heater	YES
Compressor With Electric Heater	NO
Outdoor Fin Coating	Acrylic Resin
Intelligent Defrosting	YES
Intelligent Preheating	YES
Low Voltage Startup	YES
Memory/Power Failure Recovery	YES
Self Diagnosis	YES
Low Ambient Cooling	YES
Internal Condensate Pump	YES
XK60 Wired Controller Interface	YES
Wi-Fi Interface	NO
Indoor Fan Type	Centrifugal
Multi Fan Speeds	3 Speeds
LED Display Indoor Unit	NO
Advance Filter	NO
Auxiliary Electrical Heater	NO
Ventilation (Outdoor Air)	Optional

**WIRED CONTROLLER FUNCTIONS**

Auto Mode	YES
Auto Fan	YES
Auto Swing (Continuous Sweep)	NO
Adjustable Swing Louvers (5 pos.)	NO
Clock on Remote Controller	YES
Dry Mode	YES
Dry Anti-Mildew (X-Fan) Mode	YES
Energy Saving Mode	NO
Dirty Filter Alert	NO
I Feel Function	YES
Lock on Wired Controller	YES
Quiet Mode	NO
Room Temperature Display (5 sec.)	YES
Sleep Mode	YES
Timer Mode	YES
Turbo Mode	YES
Display On/Off Control	NO
Freeze Guard Mode	YES

**FAN PERFORMANCE CURVES**

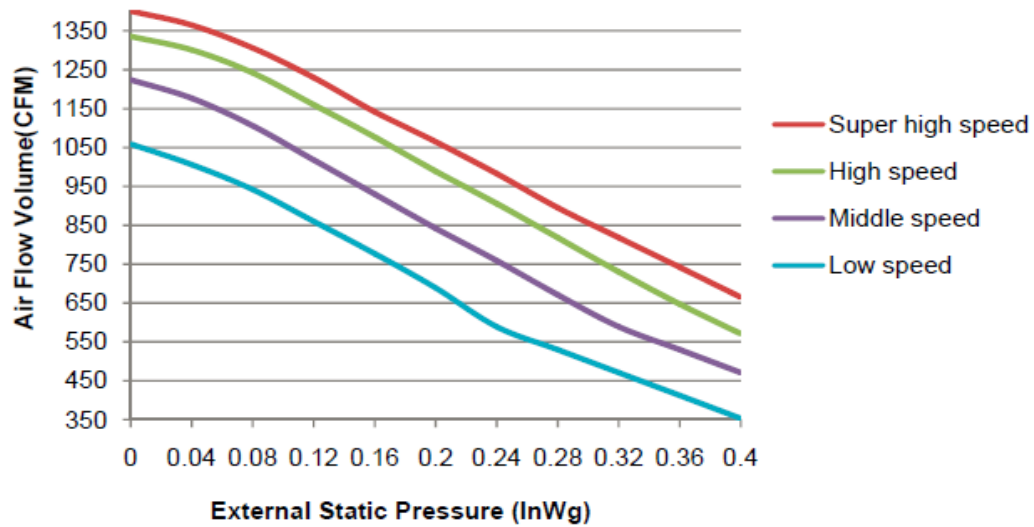

**EXTENDED RATINGS**

**COOLING PERFORMANCE**

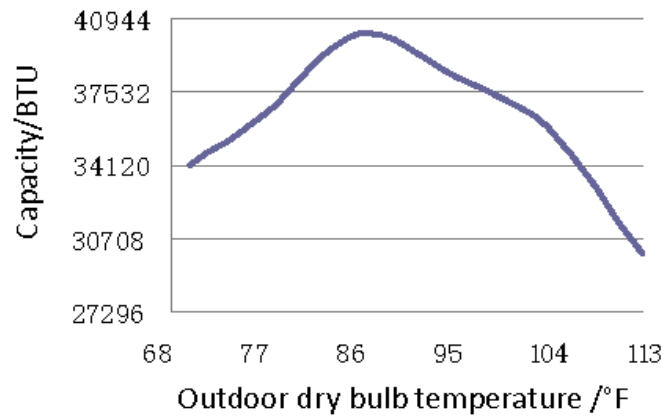

**HEATING PERFORMANCE**

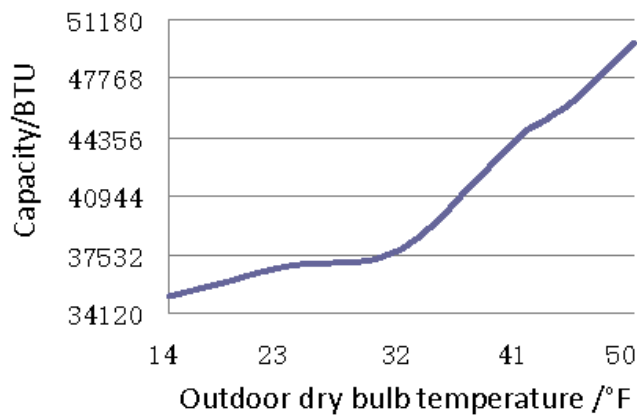

**MINIMUM SPACING REQUIREMENTS**

Units: inch (mm)

**INDOOR**

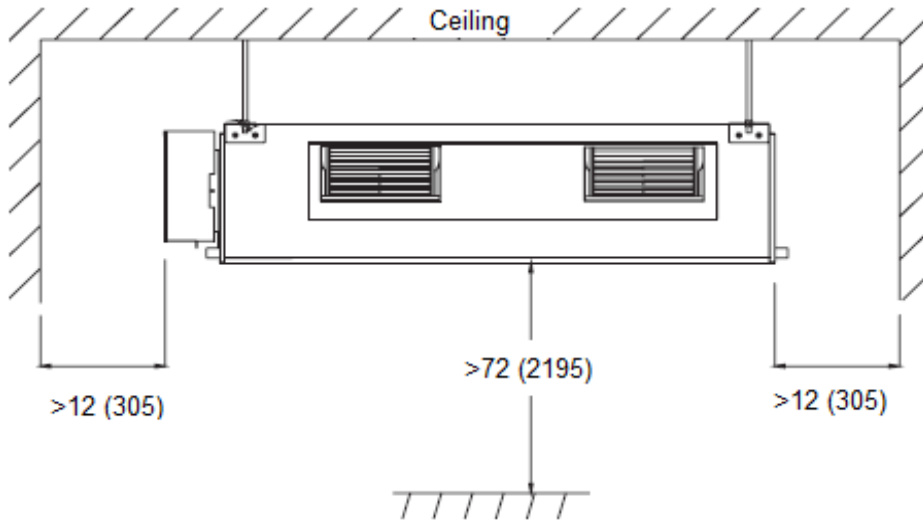

Units: inch (mm)

**OUTDOOR**

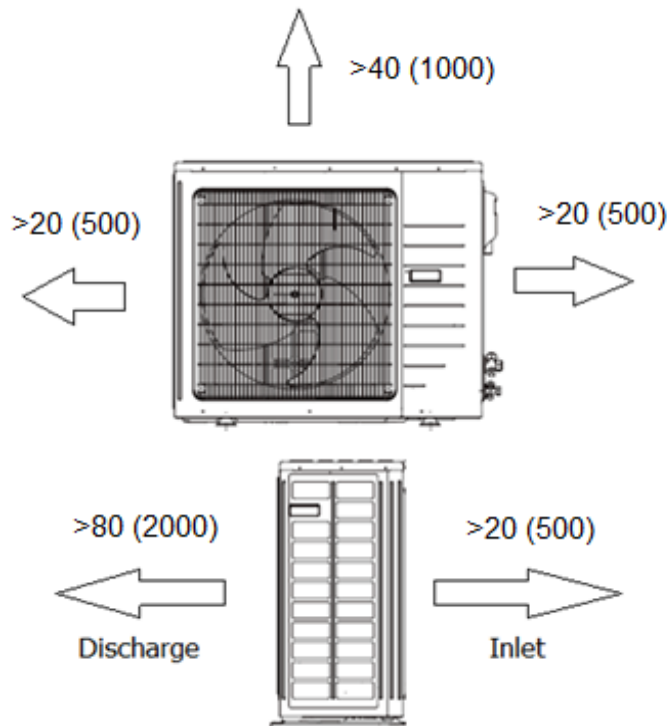

## DIMENSIONAL SPECIFICATIONS

**SC-42CD-UM**

### INDOOR UNIT DIMENSIONS & WEIGHTS

Units: inch (mm)

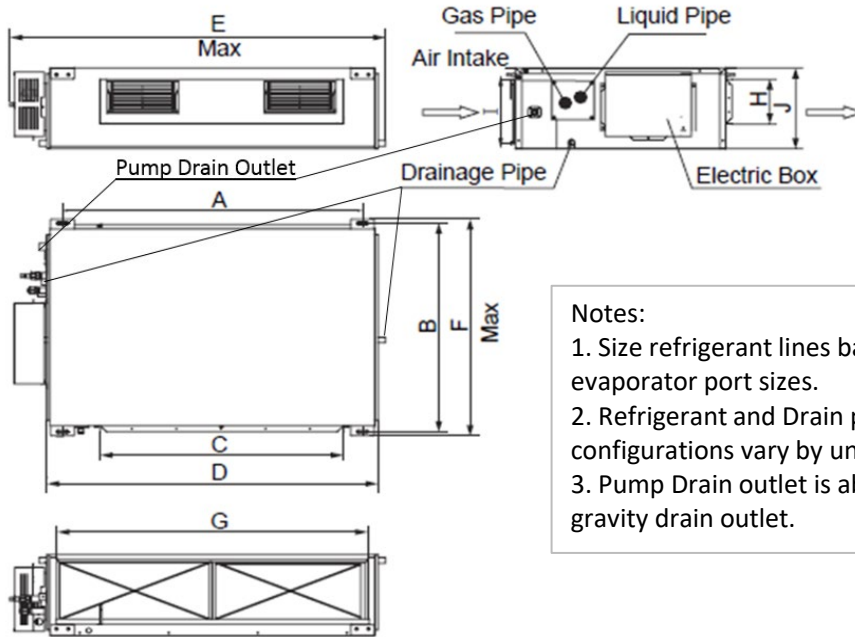

**Notes:**  
 1. Size refrigerant lines based on evaporator port sizes.  
 2. Refrigerant and Drain pipe configurations vary by unit size.  
 3. Pump Drain outlet is above gravity drain outlet.

A	39.75	(1011)
B	29.5	(748)
C	32.25	(820)
D	43.875	(1115)
E	48.25	(1226)
F	30.5	(775)
G	38.5	(979)
H	6.25	(160)
I	9.125	(231)
J	11.375	(290)

Net Weight	101.2 lbs
Shipping Weight	116.6 lbs

Liquid Line Valve	3/8-in OD Flared
Gas Line Valve	5/8-in OD Flared
Drain Connector	13/16 in OD

### OUTDOOR UNIT DIMENSIONS & WEIGHTS

Units: inch (mm)

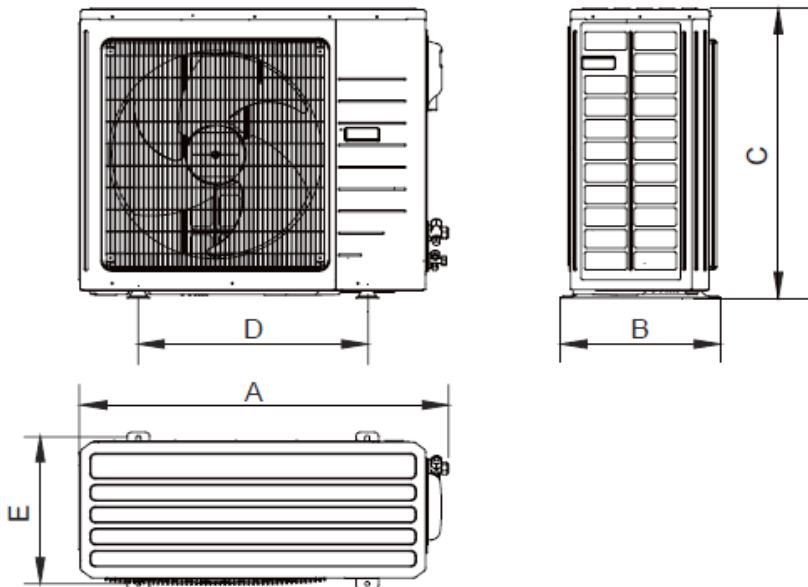

A	37.75	(958)
B	16.25	(412)
C	53.125	(1349)
D	22.5	(572)
E	14.75	(376)

Net Weight	209.0 lbs
Shipping Weight	232.0 lbs

Liquid Line Valve	3/8-in OD Flared
Gas Line Valve	5/8-in OD Flared

- Notes:**
1. Recommended Communication Wire Type 18-2 AWG Stranded Copper THHN 300V Wire
  2. Power wiring size must comply with applicable national and local codes.
  3. Test conditions are based on AHRI 210/240.

Specifications are subject to change without notice. Manufacturer reserves the right to discontinue or modify specifications or designs without notice or without incurring obligations. All rights reserved.