

DIMENSIONAL SPECIFICATIONS

INDOOR UNIT DIMENSIONS

Units: inch

Model No: SC-09WPL-HP230

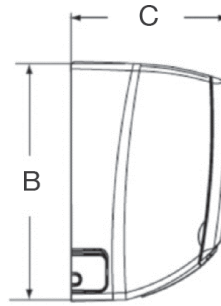
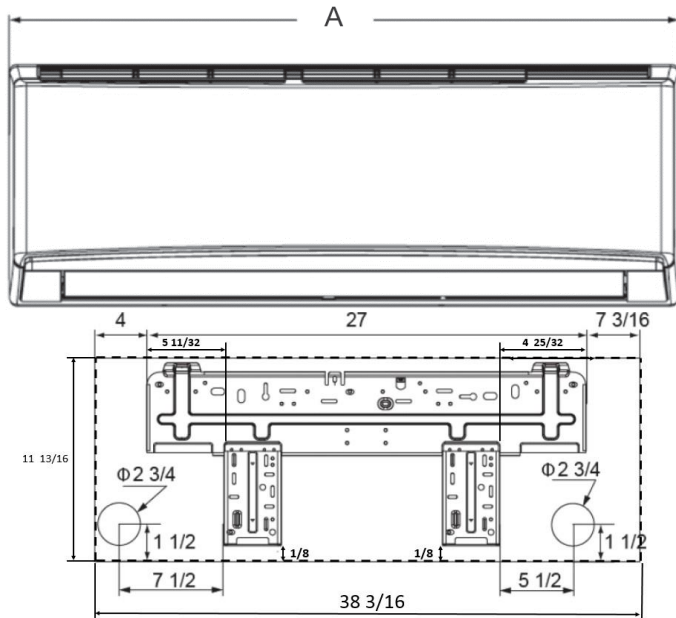

Dimensions	
A	39 1/2
B	12
C	8 7/8

Weight (Net/Shipping) 29 / 35 LBS

Liquid Line Valve	1/4-in OD Flared
Gas Line Valve	1/2-in OD Flared
Drain Connector	5/8-in OD

OUTDOOR UNIT DIMENSIONS

Units: inch

Model No: SC-09WPL-HP230

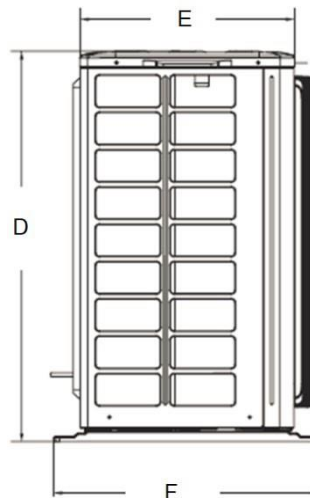
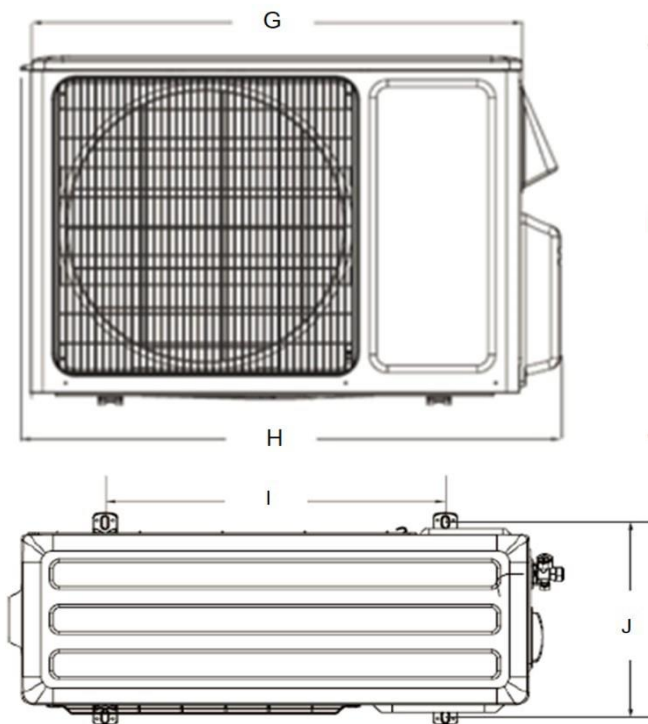

Dimensions	
D	23 1/2
E	12
F	14 3/4
G	33 1/4
H	35
I	19 1/4
J	13 1/2

Liquid Line Valve	1/4-in OD Flared
Gas Line Valve	1/2-in OD Flared

Weight (Net/Shipping) 100 / 106 LBS

Notes:

1. Recommended Interconnecting Cable Type 14 AWG 4 Stranded Copper Conductors THHN 600V Wire
2. Power wiring cable size must comply with applicable national and local codes.
3. Test conditions are based on AHRI 210/240.